

# JUVENILE SPRING CHINOOK MIGRATION IN THE MIDDLE FORK WILLAMETTE RIVER AND USE OF LOOKOUT POINT RESERVOIR

Principal Investigators:

Fred R. Monzyk  
Jeremy D. Romer  
Thomas A. Friesen

Oregon Department of Fish and Wildlife  
Corvallis Research Lab  
Corvallis, Oregon



# Objectives

- Evaluate migration timing and size of Chinook entering reservoir
- Chinook fry distribution along nearshore habitat
- Vertical distribution of Chinook near dam
- Dam passage timing patterns



# Methods

Above reservoir



Nearshore sampling

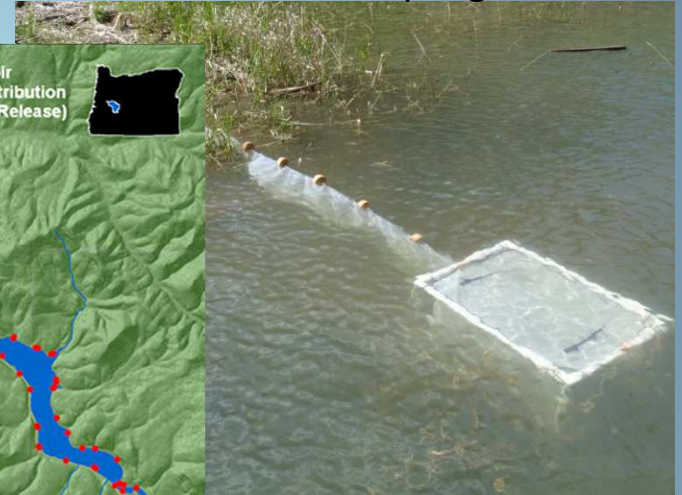
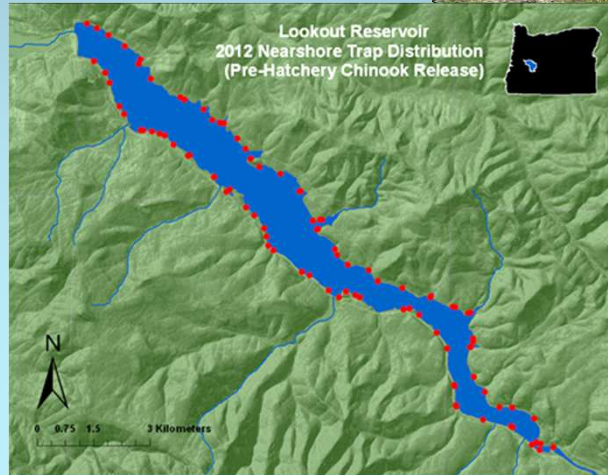

Gill netting near dam

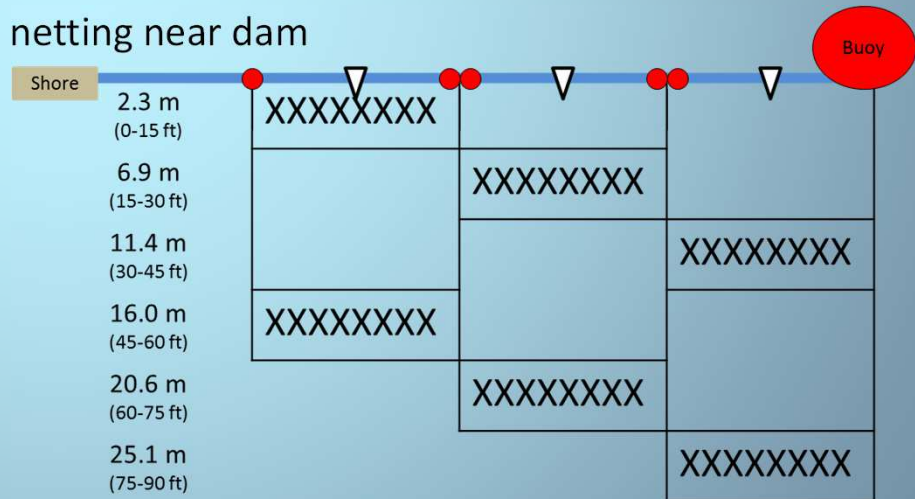

- Hung off 'rope boom' at dam
- July-Dec
- Changed pattern twice weekly

# Results

**Migration Timing and Size of Chinook Entering Reservoir**  
**- enter mainly as “fry” in early spring**

# Migration Timing and Size of Chinook Entering Reservoir

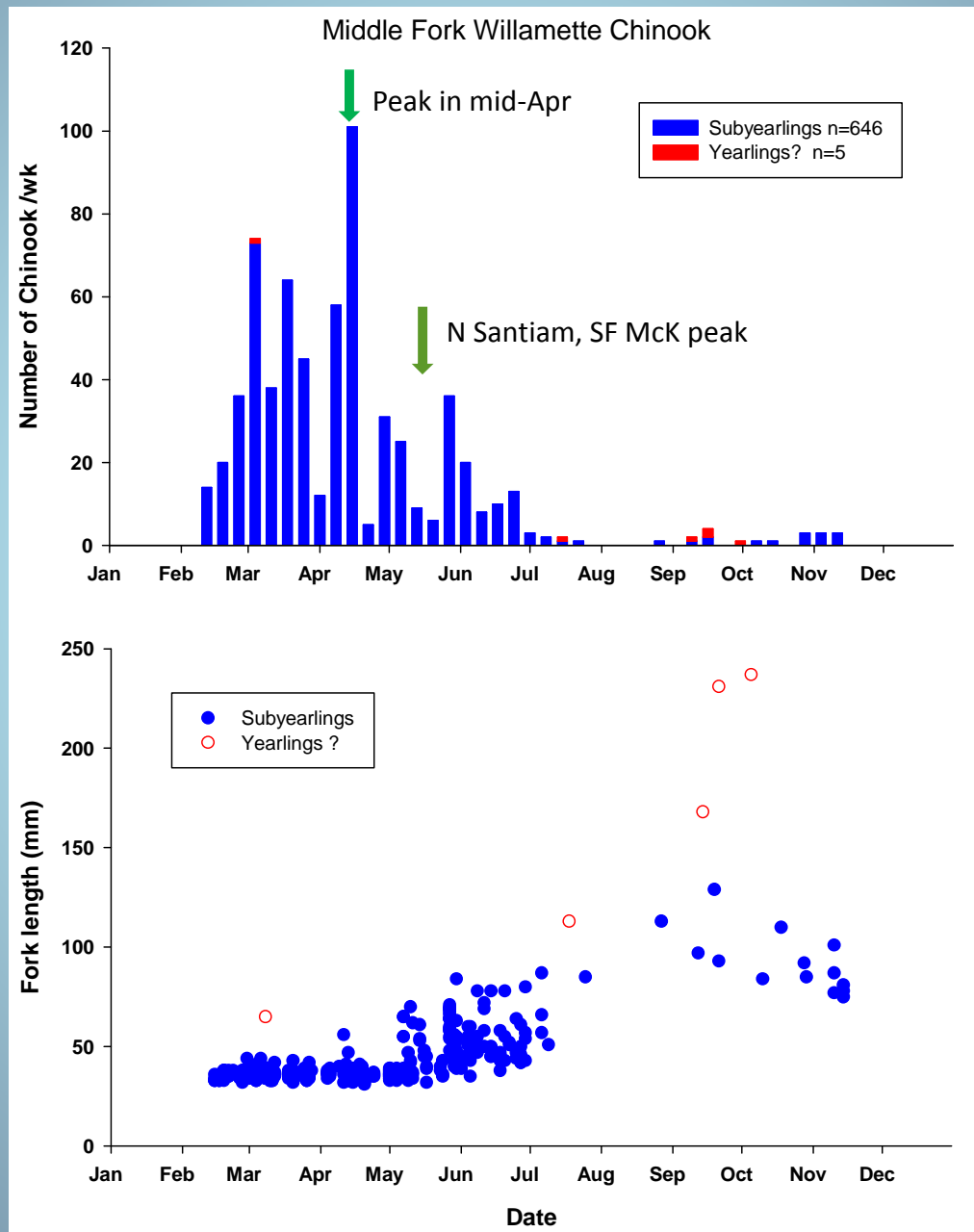

# Results

## Subyearling Nearshore Distribution

-confounded by hatchery releases in LOP

## Subyearling Nearshore Distribution

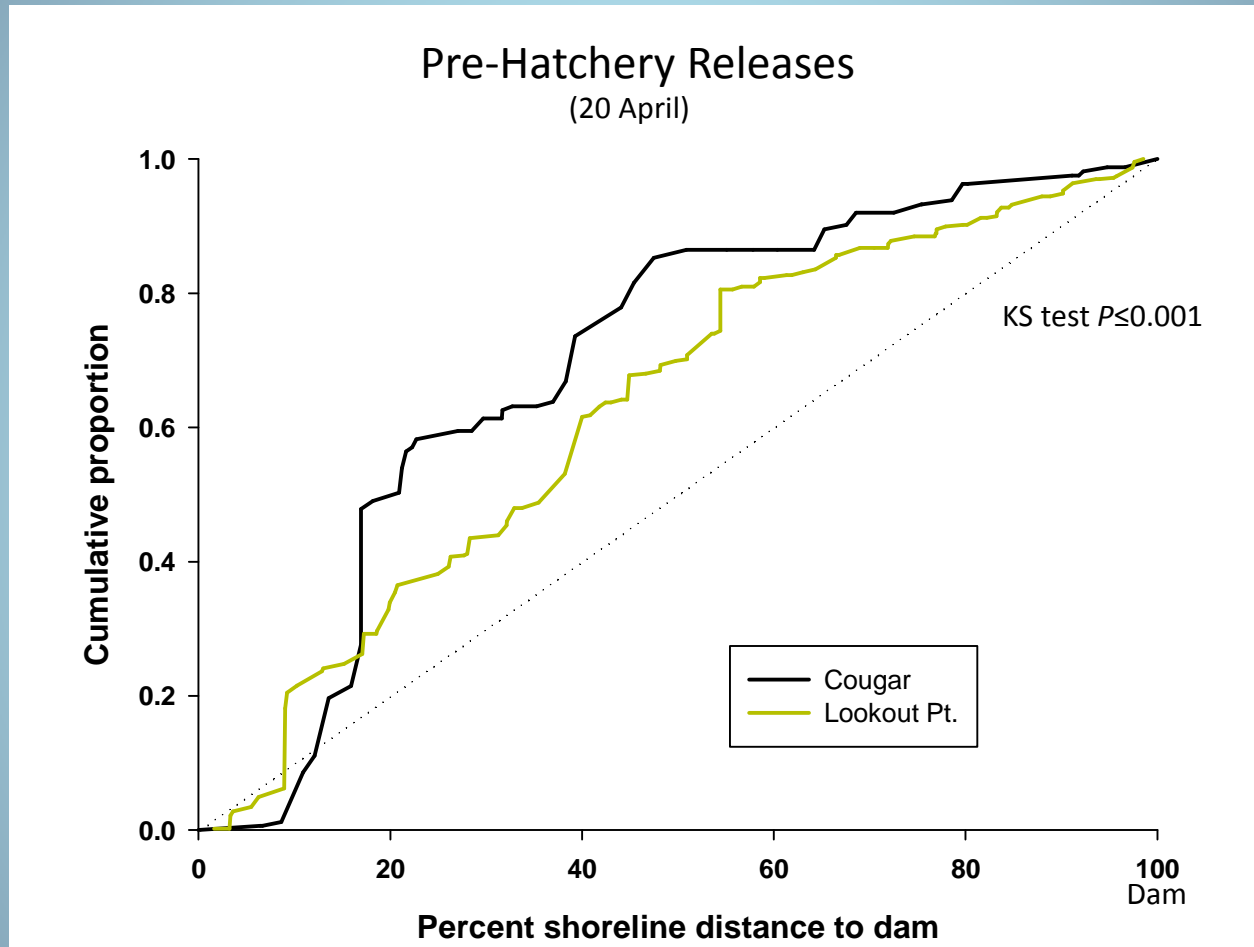

- Chinook were further dispersed into LOP compared to Cougar Reservoir by 20 Apr
- Earlier migration timing in LOP
- LOP is twice as long



# Vertical Distribution

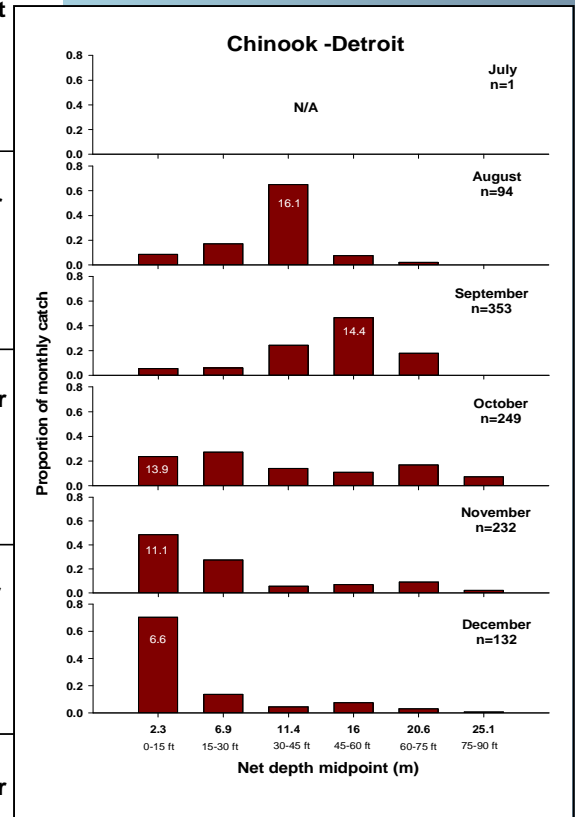
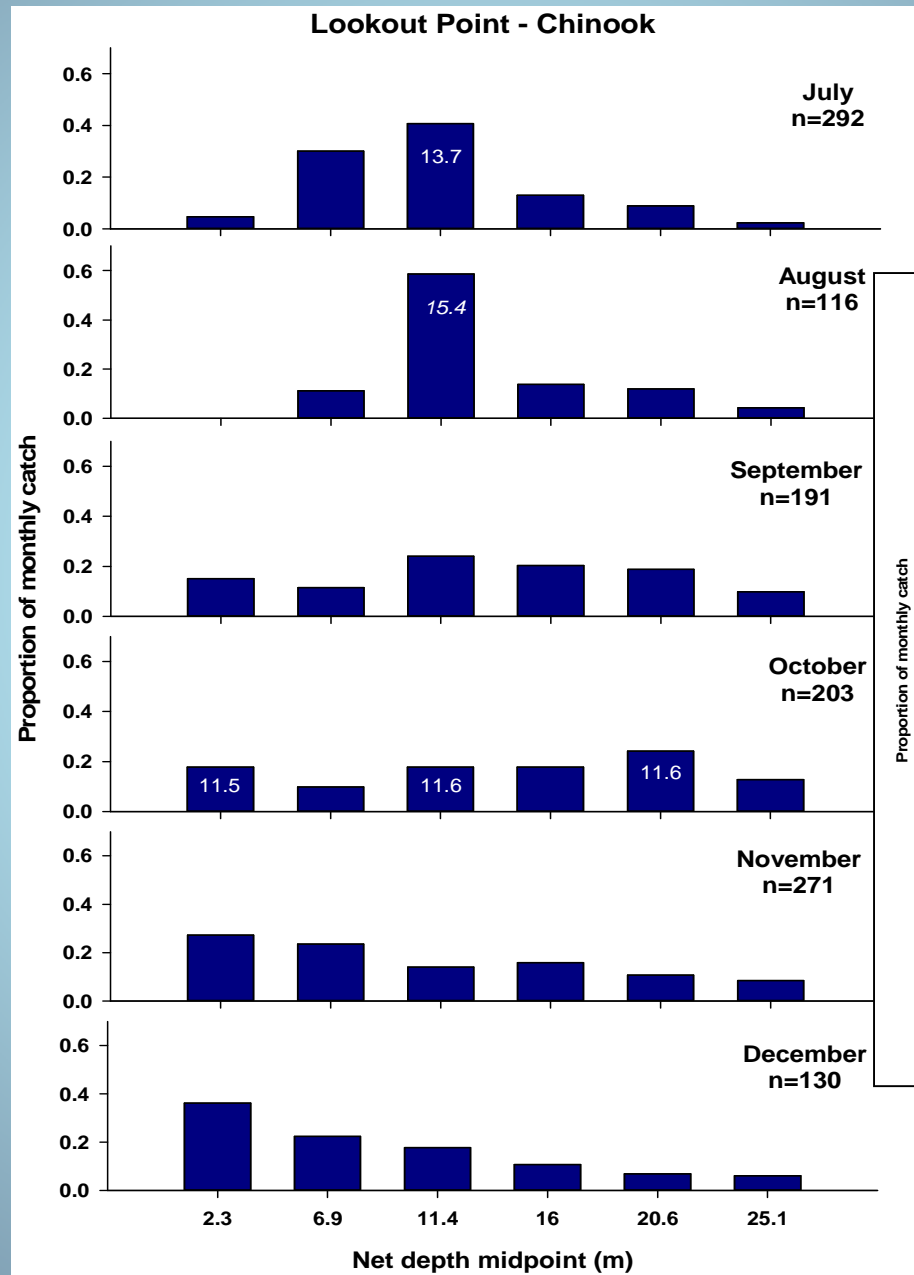



# Migration Timing and Size of Chinook Exiting Reservoir

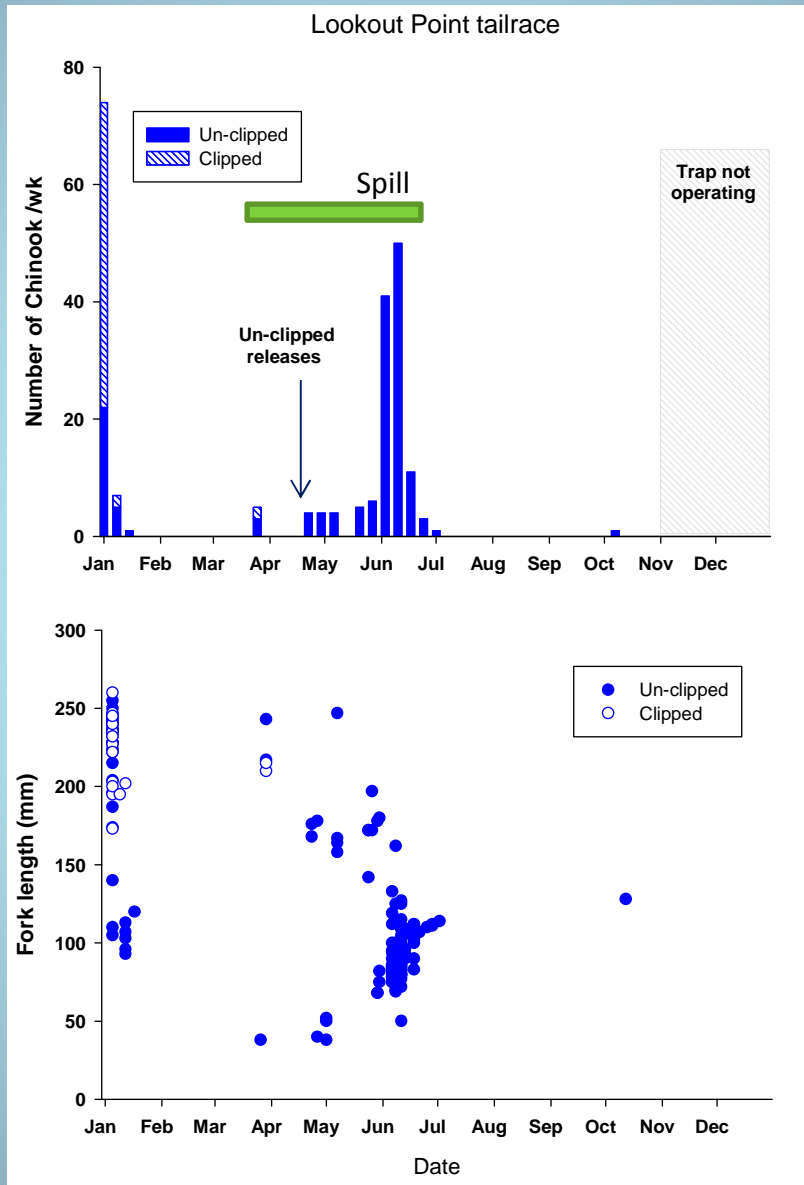

(USACE data)

# Migration Timing of Chinook Exiting Reservoir 2010-2012

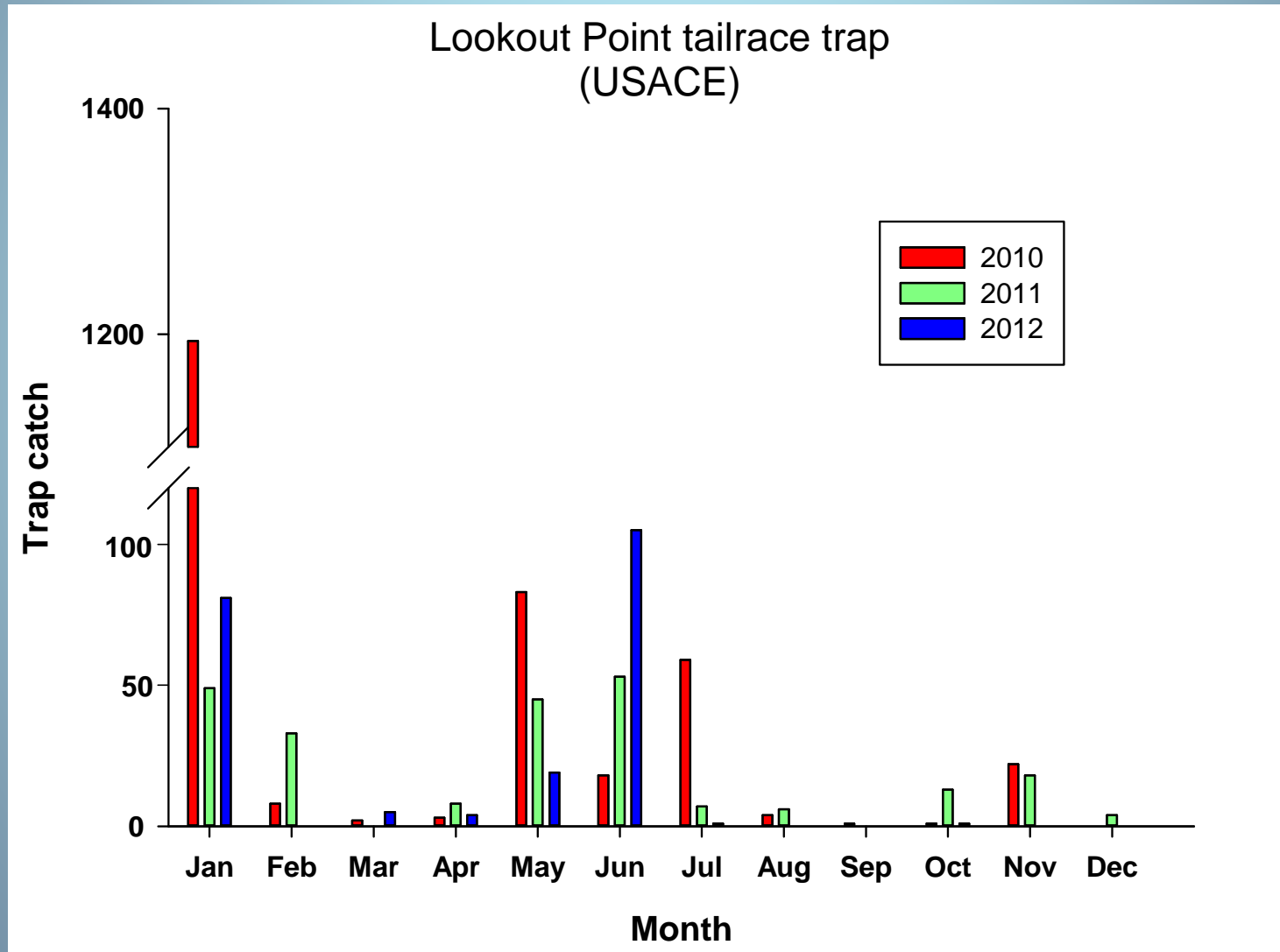

# Conclusion

- Juvenile Chinook enter Lookout Point in mostly in spring as fry
  - peak in mid-April
  - earlier than N. Santiam and SF McKenzie, later than S. Santiam
- Subyearlings dispersed further into LOP than Cougar subyearlings
- Chinook descend into deeper water (~11 m or more) in summer and return to surface in fall
  - similar to Chinook in Detroit
- Chinook exit LOP with spill in late spring and in fall/winter

# Acknowledgments

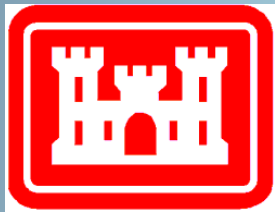

Doug Garletts  
Chad Helms  
Greg Taylor  
Rich Piaskowski



Randy Wildman



Jeff Ziller

The 'Reservoir Dogs'  
Khoury Hickman  
Chris Abbes  
Kris Clemons  
Greg Gilham  
Mario Minder  
Meghan Horne-Brine  
John Elliot  
Kevin Stertz